

DSAL

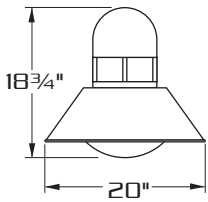

DSAL1
[175 WATT MAX.]

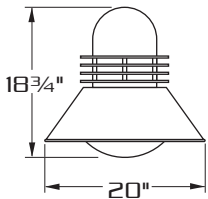

DSALB1
[175 WATT MAX.]

E.P.A. **DSAL1**= 0.89
DSALB1= 0.93



WM



1



2-180



2-90



3-90



3-120



4-90

SPECIFICATIONS

HOUSING: DURABLE HEAVY WALL CAST ALUMINUM CONSTRUCTION WITH REMOVABLE BALLAST TRAY FOR EASY BALLAST ACCESS. LUMINAIRE PROVIDED WITH UP LIGHT COMPONENT
OPTION: DECORATIVE CAST ALUMINUM RINGS.

REFLECTOR: HEAVY WALL ALUMINUM CONSTRUCTION. INSIDE OF REFLECTOR FINISHED WITH HIGH GLOSS WHITE ENAMEL.

OPTICS: DISHED OPAL ACRYLIC DIFFUSER. SYMMETRIC LIGHT DISTRIBUTION.

LAMP HOLDER: MEDIUM OR MOGUL BASE PORCELAIN.

LAMP: (BY OTHERS)

BALLAST: H.P.F./C.W.A. AUTOTRANSFORMER. -20° STARTING TEMPERATURE. ELECTRICAL COMPONENTS ARE MOUNTED TO A REMOVABLE BALLAST TRAY. BALLAST IS EQUIPPED WITH FACTORY INSTALLED QUICK DISCONNECT PLUG.

FINISH: POLYESTER POWDER COAT-STATE OF THE ART 20 PSI PRESSURE POWER WASH AT 140° TEMPERATURE INCORPORATES FOUR STEP IRON PHOSPHATE PROCESS TO CLEANSE AND PRETREAT THE METAL SURFACE FOR MAXIMUM PAINT ADHESION. ELECTROSTATICALLY APPLIED TEXTURED POLYESTER POWDER TOPCOAT IS BAKED AT 400° TEMPERATURE FOR MAXIMUM HARDNESS AND EXTERIOR DURABILITY.



660 WEST AVENUE O, PALMDALE, CA. 93551
(661) 233-2000
FAX NO. (661) 233-2001
www.usaltg.com

B1-5
REV. 10 / 03

MOUNTING STYLES

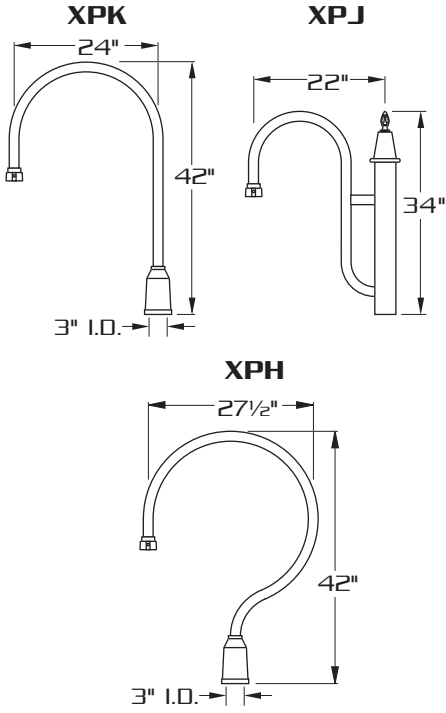

AVAILABLE FOR MOUNTING 1 ONLY

ARMS ARE HEAVY WALL EXTRUDED ALUMINUM CONSTRUCTION. FOR ADDITIONAL ARM OPTIONS SEE ARM SECTION.

WALL MOUNT

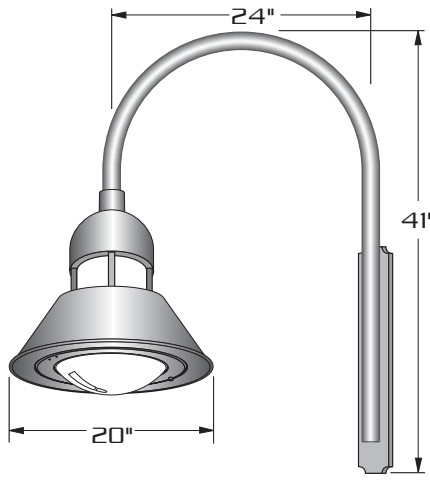

EXTRUDED AND CAST ALUMINUM CONSTRUCTION.

WALL PLATE

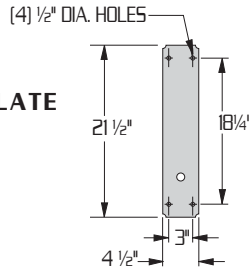

**LAMP SIZE:
50 - 175 WATT**

E.P.A. = 0.89

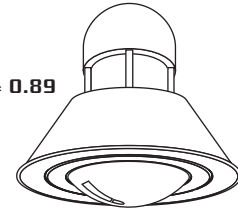

DSAL1
[175 W. MAX.]

E.P.A. = 0.93



DSALB1
[175 W. MAX.]

CAST ALUMINUM HOUSING.

INTEGRAL, SELF CONTAINED BALLAST COMPARTMENT.

ORDERING INFORMATION

| MODEL NO. : DSAL | OPTICS | WATTAGE TYPE VOLTAGE | MOUNTING | FINISH | OPTIONS |
|-----------------------------------|--|--|---|---|---|
| MODEL NO. : DSAL | OPTICS | LAMP | MOUNTING | FINISH | OPTIONS |
| D S A L | STANDARD: | WATTAGE TYPE VOLTAGE | <input type="checkbox"/> XPK <input type="checkbox"/> XPJ | <input type="checkbox"/> DARK BRONZE DBM | <input type="checkbox"/> 3/8" IPS STEM MOUNT AND SWIVEL CANOPY (4'-0" MAX.) SM |
| | <input type="checkbox"/> OPAL ACRYLIC WA | <input type="checkbox"/> 175 <input type="checkbox"/> HPS <input type="checkbox"/> 120 | <input type="checkbox"/> XPH | <input type="checkbox"/> MEDIUM BRONZE MBM | <input type="checkbox"/> CHAIN MOUNTED (4'-0" MAX.) CM |
| | OPTIONS: | <input type="checkbox"/> 150 <input type="checkbox"/> MH <input type="checkbox"/> 208 | <input type="checkbox"/> WM ● | <input type="checkbox"/> BLACK BKM | <input type="checkbox"/> HOUSE SIDE SHIELD 90° HS 90° 135° HS 135° 180° HS 180° |
| | <input type="checkbox"/> CLEAR ACRYLIC CA | <input type="checkbox"/> 100 <input type="checkbox"/> MV <input type="checkbox"/> 240 | <input type="checkbox"/> 1 ● | <input type="checkbox"/> WHITE WTM | <input type="checkbox"/> PHOTO CELL + VOLTAGE (EXAMPLE: PC120V) PC+V |
| | <input type="checkbox"/> OPAL POLYCARBONATE WP | <input type="checkbox"/> 75 <input type="checkbox"/> 277 | | <input type="checkbox"/> SILVER SLM | <input type="checkbox"/> SINGLE FUSE (120V., 277V) SF |
| | <input type="checkbox"/> CLEAR POLYCARBONATE CP | <input type="checkbox"/> 70 <input type="checkbox"/> 480 | | | <input type="checkbox"/> DOUBLE FUSE (208V., 240V) DF |
| | | <input type="checkbox"/> 50 <input type="checkbox"/> MT | | | |
| | | | SEE ARM SECTION FOR ADDITIONAL ARMS | SEE PAGE 3 FOR ADDITIONAL COLORS | |



660 WEST AVENUE O, PALMDALE, CA. 93551
(661) 233-2000
FAX NO. (661) 233-2001
www.usaltg.com