

# DSA

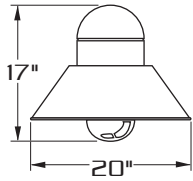

**DSA1**  
[175 WATT MAX.]

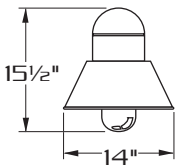

**DSA2**  
[100 WATT MAX.]

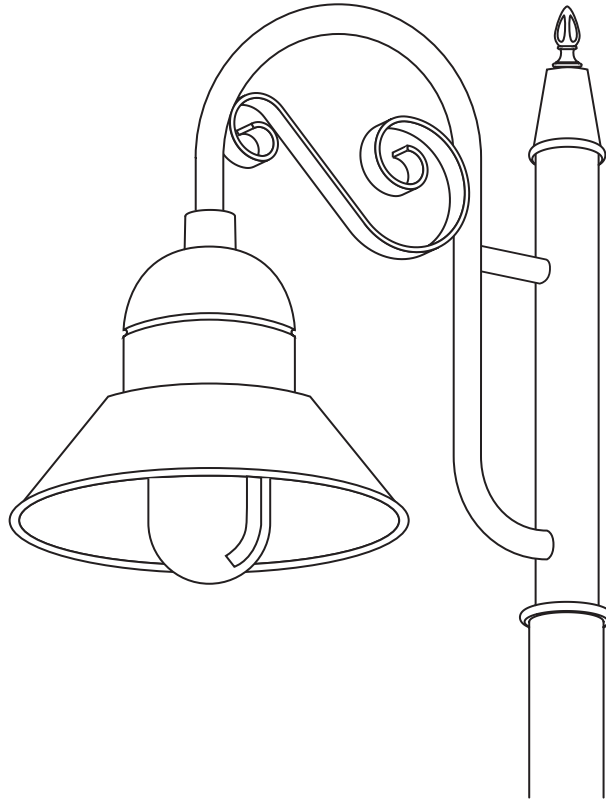

E.P.A. **DSA1**= 0.83  
**DSA2**= 0.65



WM



1



2-180



2-90



3-90



3-120



4-90

## SPECIFICATIONS

**HOUSING:** ONE PIECE HEAVY WALL ALUMINUM CONSTRUCTION WITH REMOVABLE BALLAST TRAY FOR EASY BALLAST ACCESS.

**REFLECTOR:** HEAVY WALL ALUMINUM CONSTRUCTION. INSIDE OF REFLECTOR FINISHED IN HIGH GLOSS WHITE ENAMEL FOR MAXIMUM REFLECTANCE.

**OPTICS:** CLEAR PRISMATIC TEMPERED GLASS DIFFUSER.  
**OPTION:** OPAL GLASS DIFFUSER

**LAMP HOLDER:** MEDIUM BASE PORCELAIN.

**LAMP:** (BY OTHERS)

**BALLAST:** H.P.F./C.W.A. AUTOTRANSFORMER. -20° STARTING TEMPERATURE. ELECTRICAL COMPONENTS ARE MOUNTED TO A REMOVABLE BALLAST TRAY. BALLAST IS EQUIPPED WITH FACTORY INSTALLED QUICK DISCONNECT PLUG.

**FINISH:** POLYESTER POWDER COAT-STATE OF THE ART 20 PSI PRESSURE POWER WASH AT 140° TEMPERATURE INCORPORATES FOUR STEP IRON PHOSPHATE PROCESS TO CLEANSE AND PRETREAT THE METAL SURFACE FOR MAXIMUM PAINT ADHESION. ELECTROSTATICALLY APPLIED TEXTURED POLYESTER POWDER TOPCOAT IS BAKED AT 400° TEMPERATURE FOR MAXIMUM HARDNESS AND EXTERIOR DURABILITY.



**MOUNTING STYLES**

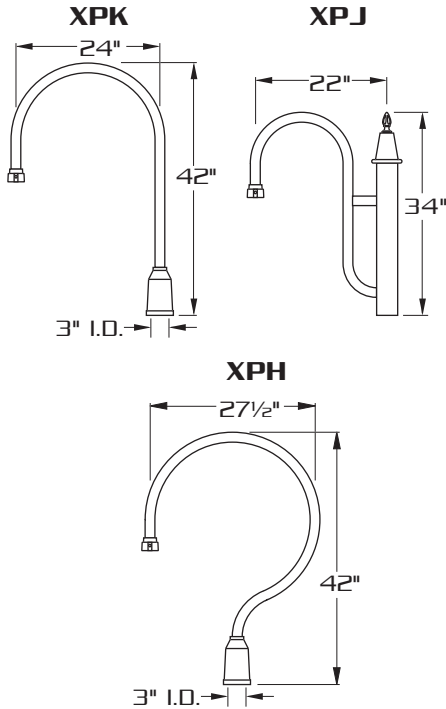

AVAILABLE FOR MOUNTING 1 ONLY

ARMS ARE HEAVY WALL EXTRUDED ALUMINUM CONSTRUCTION. FOR ADDITIONAL ARM OPTIONS SEE ARM SECTION.

**WALL MOUNT**

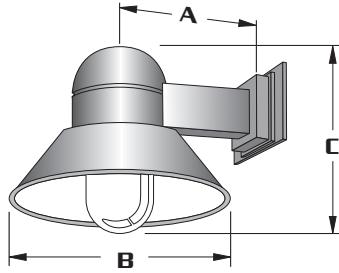

LUM.	A	B	C
DSA1	14"	20"	17"
DSA2	13"	14"	15 1/2"

EXTRUDED ALUMINUM ARM AND CAST ALUMINUM WALL BRACKET ASSEMBLY PROVIDED WITH BUILT IN GASKETED WIRE ACCESS FOR FIXTURE/SUPPLY WIRE CONNECTION.

**WALL PLATE**

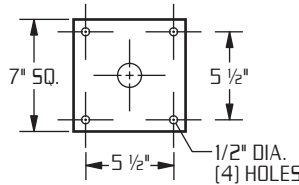

**LAMP SIZE:  
50 - 175 WATT**

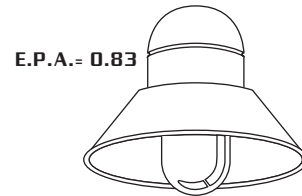

E.P.A.= 0.83

**DSA1**  
(175 WATT MAX.)



E.P.A.= 0.65

**DSA2**  
(100 WATT MAX.)

ALL ALUMINUM CONSTRUCTION.

INTEGRAL, SELF CONTAINED BALLAST COMPARTMENT.

THREE MOUNTING STYLES.

**ORDERING INFORMATION**

MODEL NO. : DSA	OPTICS	WATTAGE TYPE VOLTAGE	MOUNTING	FINISH	OPTIONS
--------------------	--------	----------------------	----------	--------	---------

MODEL NO. : <b>DSA</b>	OPTICS	LAMP	MOUNTING	FINISH	OPTIONS
	<p><b>STANDARD:</b></p> <input type="checkbox"/> CLEAR PRISMATIC TEMPERED GLASS CPG	<p>WATTAGE TYPE VOLTAGE</p> <input type="checkbox"/> 175 <input type="checkbox"/> HPS <input type="checkbox"/> 120 <input type="checkbox"/> 150 <input type="checkbox"/> MH <input type="checkbox"/> 208 <input type="checkbox"/> 100 <input type="checkbox"/> MV <input type="checkbox"/> 240 <input type="checkbox"/> 75 <input type="checkbox"/> 277 <input type="checkbox"/> 70 <input type="checkbox"/> 480 <input type="checkbox"/> 50 <input type="checkbox"/> MT	<input type="checkbox"/> XPK <input type="checkbox"/> XPJ <input type="checkbox"/> XPH <input type="checkbox"/> WM ..... ● <input type="checkbox"/> 1 ..... ●	<input type="checkbox"/> DARK BRONZE DBM <input type="checkbox"/> MEDIUM BRONZE MBM <input type="checkbox"/> BLACK BKM <input type="checkbox"/> WHITE WTM <input type="checkbox"/> SILVER SLM	<input type="checkbox"/> 3/8" IPS STEM MOUNT AND SWIVEL CANOPY (4'-0" MAX.) ..... SM <input type="checkbox"/> CHAIN MOUNTED (4'-0" MAX.) ..... CM <input type="checkbox"/> HOUSE SIDE SHIELD 90° ..... HS 90° 135° ..... HS 135° 180° ..... HS 180° <input type="checkbox"/> PHOTO CELL + VOLTAGE (EXAMPLE: PC120V) ..... PC+V <input type="checkbox"/> SINGLE FUSE (120V., 277V) ..... SF <input type="checkbox"/> DOUBLE FUSE (208V., 240V) ..... DF
	<p><b>OPTIONS:</b></p> <input type="checkbox"/> OPAL GLASS DIFFUSER WGD [ANNEALED & HEAT RESISTANT]	<p>MEDIUM BASE LAMP ONLY</p> <p>DSA2- 100 W. MAX.</p>	<p>SEE ARM SECTION FOR ADDITIONAL ARMS</p>	<p><b>OPTION:</b></p> <input type="checkbox"/> ANODIZED AZ ANODIZED HOUSING MUST HAVE PAINT FINISH COAT EXAMPLE: AZDBM	



660 WEST AVENUE O, PALMDALE, CA. 93551

(661) 233-2000  
FAX NO. (661) 233-2001

www.usaltg.com