

AEROLUME-G™

(1000 WATT MAX.)

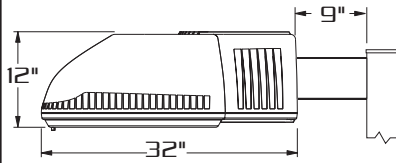

SIDE VIEW

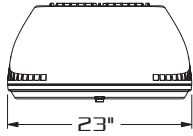

FRONT VIEW

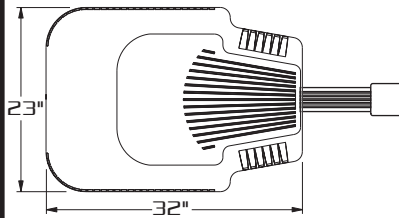

TOP VIEW

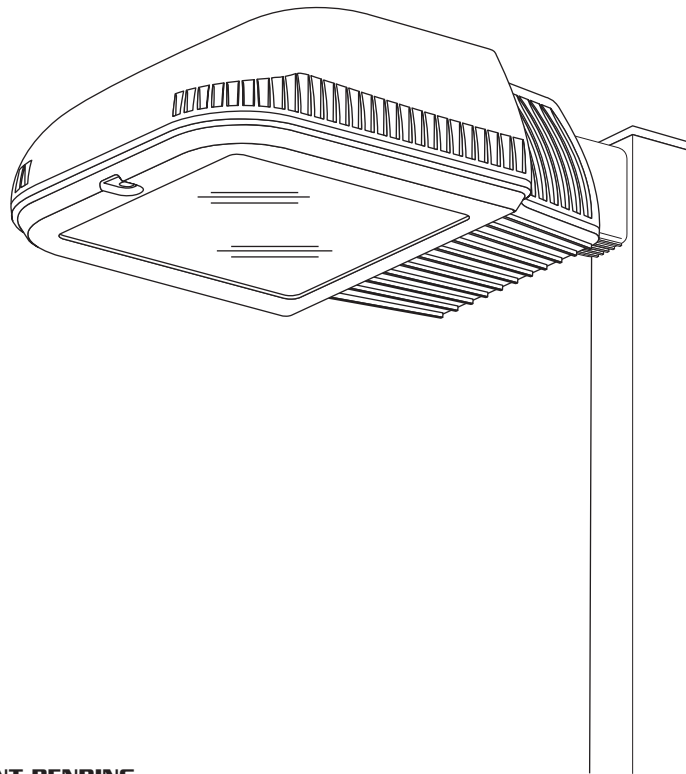

PATENT PENDING

E.P.A.- 2.75



WM



1



2-180



2-90



3-90



3-120



4-90

SPECIFICATIONS

HOUSING: PRECISE, ONE PIECE CAST ALUMINUM CONSTRUCTION. AERODYNAMIC STYLING OF HOUSING AND BALLAST COMPARTMENT FEATURES RIBBED DETAILS WHICH DISSIPATES HEAT FROM LUMINAIRE INTERIOR TO INCREASE BOTH BALLAST AND LAMP LIFE.

LENS ASS'Y: PRECISE, ONE PIECE CAST ALUMINUM CONSTRUCTION. DOOR FRAME ENCASES 3/16" CLEAR TEMPERED GLASS LENS SEALED TO DOOR FRAME WITH HIGH TEMPERATURE EPDM GASKET TO COMPLETELY SEAL DOOR FRAME FROM CONTAMINANTS. QUARTER TURN FASTENER DISENGAGES LENS ASSEMBLY AND ACTIVATES ACCULATCH™ HINGE TO ALLOW LENS ASSEMBLY TO HINGE AWAY FROM HOUSING FOR LUMINAIRE ACCESS WITHOUT THE USE OF TOOLS.

OPTICS: PRECISION SEGMENTED OPTICS PRODUCE WIDE THROW. HIGHLY UNIFORM LIGHT DISTRIBUTIONS. FULL CUTOFF AVAILABLE WITH HORIZONTAL LAMP OPTICS AND FLAT GLASS LENS. REFLECTOR ASSEMBLIES ARE FIELD ROTATABLE IN 90° INCREMENTS.

GASKETING: CLOSED CELL EPDM GASKETING COMPRESSED BETWEEN DOOR AND HOUSING WORKS IN COMBINATION WITH ACCULATCH™ HINGE TO PRESSURE SEAL OPTICAL CHAMBER.

LAMP HOLDER: MOGUL BASE PORCELAIN. LAMPHOLDER EQUIPPED WITH FACTORY INSTALLED QUICK DISCONNECT PLUG.

LAMP: (BY OTHERS)

BALLAST: ELECTRICAL COMPONENTS ARE FACTORY PREWIRED WITH QUICK-DISCONNECT PLUGS, AND ARE MOUNTED TO A ONE PIECE HINGED BALLAST PLATE. BALLAST PLATE DISENGAGES FROM HOUSING WITHOUT USE OF TOOLS. BALLAST PLATE HINGES AND IS REMOVABLE FOR SERVICING.

ARM: 3"X5"X9" LONG HEAVY WALL EXTRUDED ALUMINUM. ARM IS DESIGNED WITH SOFT CORNERS AND HORIZONTAL RIBS TO COMPLIMENT STYLING ON HOUSING AND DOOR FRAME.

HARDWARE: ALL EXPOSED HARDWARE IS STAINLESS STEEL.

FINISH: POLYESTER POWDER COAT-STATE OF THE ART 20 PSI PRESSURE POWER WASH AT 140° TEMPERATURE INCORPORATES FOUR STEP IRON PHOSPHATE PROCESS TO CLEANSE AND PRETREAT THE METAL SURFACE FOR MAXIMUM PAINT ADHESION. ELECTROSTATICALLY APPLIED TEXTURED POLYESTER POWDER TOP COAT IS BAKED AT 400° TEMPERATURE FOR MAXIMUM HARDNESS AND EXTERIOR DURABILITY.



660 WEST AVENUE O, PALMDALE, CA. 93551

(661) 233-2000

FAX NO. (661) 233-2001

www.usaltg.com

A1-5

TYPICAL SQUARE POLE TEMPLATE

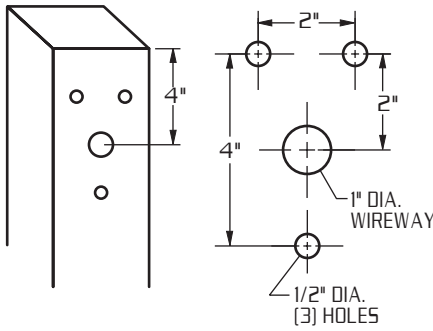

TYPICAL ROUND POLE TEMPLATE

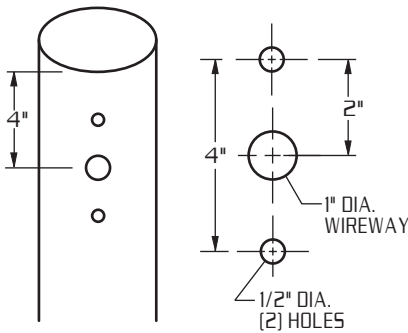

HORIZONTAL

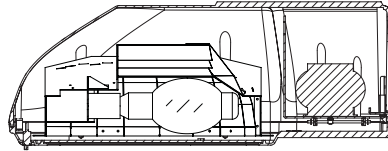

E.P.A.- 2.37

E.P.A.- 2.75
(WITH ARM)

VERTICAL

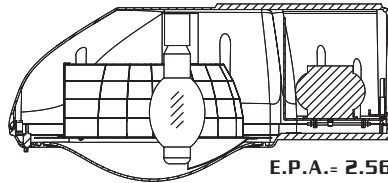

E.P.A.- 2.56

E.P.A.- 2.94
(WITH ARM)

VERTICAL LAMP REFLECTOR
REQUIRES CONVEX GLASS

**LAMP SIZE:
400 - 1000 WATT**

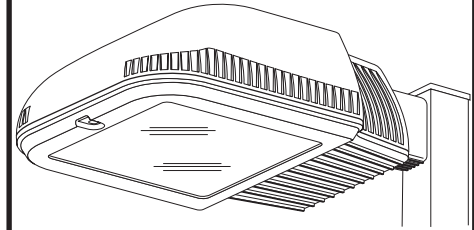

PATENT PENDING

**PRECISE, ONE PIECE CAST
DIE CAST ALUMINUM HOUSING
AND DOOR FRAME.**

**OPTICAL SYSTEM ENCLOSED
IN IMPACT RESISTANT
TEMPERED GLASS LENS.**

**REFLECTOR IS ENTIRELY
FIELD ROTATABLE.**

**TOOLESS ENTRY TO LUMINAIRE
HOUSING.**

**BALLAST TRAY IS HINGED
AND REMOVABLE WITHOUT
THE USE OF TOOLS FOR
EASY ACCESS TO ELECTRICAL
COMPONENTS.**

ORDERING INFORMATION

MODEL NO. : AER-G	OPTICS	WATTAGE TYPE VOLTAGE	MOUNTING	FINISH	OPTIONS
----------------------	--------	----------------------	----------	--------	---------

MODEL NO. :	OPTICS	LAMP	MOUNTING	FINISH	OPTIONS	
A E R - G	HORIZONTAL LAMP	WATTAGE/TYPE	VOLTAGE	ARM MOUNT	<input type="checkbox"/> DARK BRONZE DBM	<input type="checkbox"/> CLEAR POLYCARBONATE DIFFUSER LEX
	<input type="checkbox"/> TYPE II HR-II.....	<input type="checkbox"/> 1000 MH (BT37)	<input type="checkbox"/> 120	<input type="checkbox"/> 1	<input type="checkbox"/> MEDIUM BRONZE MBM	<input type="checkbox"/> HOUSE SIDE SHIELD HS
	<input type="checkbox"/> TYPE III HR-III.....	<input type="checkbox"/> 1000 PSMH (BT37)	<input type="checkbox"/> 208	STREET LIGHTING ARM MOUNT	<input type="checkbox"/> BLACK BKM	<input type="checkbox"/> PHOTO CELL + VOLTAGE (EXAMPLE: PC120V) PC+V
	<input type="checkbox"/> TYPE IV-W HR-IV-W...	<input type="checkbox"/> 750 MH (BT37)	<input type="checkbox"/> 240	<input type="checkbox"/> ST 23	<input type="checkbox"/> WHITE WTM	<input type="checkbox"/> TWIST LOCK PHOTO CELL+VOLTAGE (EXAMPLE TPC120V) TPC+V
	<input type="checkbox"/> TYPE V HR-V-SQ....	<input type="checkbox"/> 750 PSMH (BT37)	<input type="checkbox"/> 277	(TO FIT OVER 2 3/8" O.D. ARM)	<input type="checkbox"/> SILVER SLM	<input type="checkbox"/> TWIST LOCK PHOTO CELL+VOLTAGE (EXAMPLE TPC120V) TPC+V
	<input type="checkbox"/> TYPE FT (REAR CUTOFF) HR-FT-HSC...	<input type="checkbox"/> 400 MH (ED37)	<input type="checkbox"/> 480	ADJUSTABLE KNUCKLE		<input type="checkbox"/> TWIST LOCK RECEPTACLE ONLY TPR
		<input type="checkbox"/> 400 PSMH (ED37)	<input type="checkbox"/> MT	<input type="checkbox"/> NKLE23		<input type="checkbox"/> SINGLE FUSE (120V. , 277V) SF
		<input type="checkbox"/> 400 MH (ED37)		(TO FIT OVER 2 3/8" O.D.)		<input type="checkbox"/> DOUBLE FUSE (208V. , 240V) DF
		<input type="checkbox"/> 400 PSMH (ED37)		<input type="checkbox"/> NKLE27		
		<input type="checkbox"/> 750 HPS (BT37)		(TO FIT OVER 2 7/8" O.D.)		
	<input type="checkbox"/> 400 HPS (ED18)			SEE PAGE 3 FOR ADDITIONAL COLORS		
	VERTICAL LAMP					
	<input type="checkbox"/> TYPE III VR-III.....					
	<input type="checkbox"/> TYPE IV VR-IV.....					
	<input type="checkbox"/> TYPE V VR-V-SQ ...					



660 WEST AVENUE O, PALMDALE, CA. 93551

(661) 233-2000
FAX NO. (661) 233-2001

www.usaltg.com